



STRUCTURAL STEEL CONNECTIONS MADE EASY

|SERIOUS|

|APPROVED|

|FIXINGS|

|EASY|



BOXBOLT the system

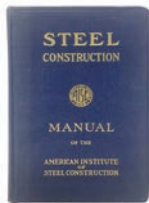

BoxBolt is designed with a sleeve that expands on the inside of the connection creating a strong geometrical interlock. It works everywhere, can be used with rectangular, square and even circular hollow sections and features a hexagon head design to aid installation with a standard spanner. When installation time needs to be kept at an absolute minimum, **BoxBolt** can be installed using the BoxSok installation tool.

BoxBolt is available in three finishes: Zinc Plated, Hot Dip Galvanised and Stainless Steel.

These finishes combined with three available lengths and multiple head styles make **BoxBolt** the most flexible solution suiting almost any environment and application.

BoxBolt is ETA assessed, is approved for use by Lloyds Register (LR) and ICC-ES rated. Thanks to all these approvals **BoxBolt** complies with the latest steel constructions codes worldwide providing the designer and the user with total confidence and peace of mind.

BoxBolt is also listed as a solution for connecting Hollow Steel Sections as referenced in the AISC manual.

BOXBOLT advantages



Best approved performance



Lowest labor cost



Easy to use



All section shapes



approved and certified loads



Aesthetic finish



Ideal for combined loads



Different corrosion resistant options

BOXBOLT technical information

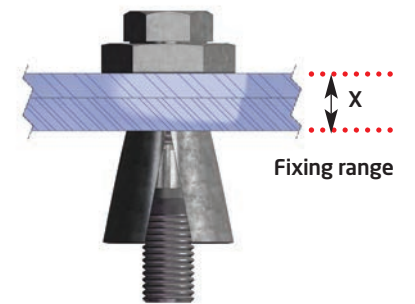
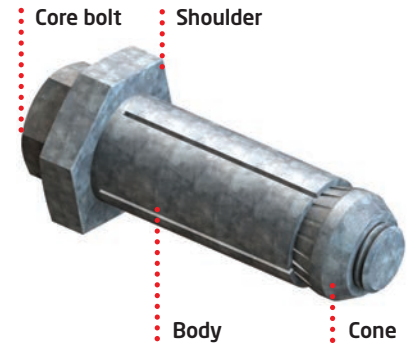

MATERIALS

Mild steel to BS EN 10083 Grade 1.1151
Stainless steel to BS EN 10088 Grade 1.4401

FINISHES

Zinc plated to BS EN 12329: Class Fe//Zn8//A
Hot Dip Spun Galvanised to BS EN ISO 1461

BOXBOLT head styles

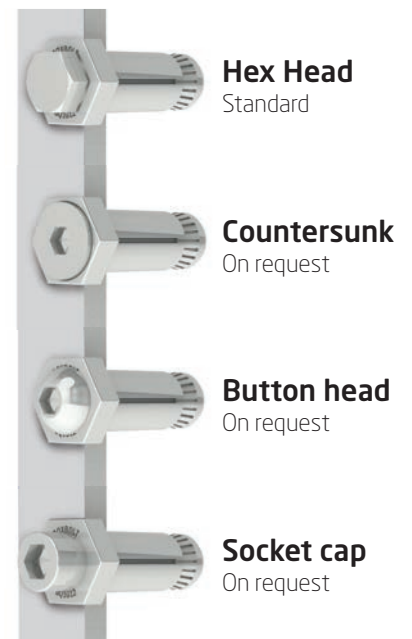



BOXBOLT range

ZINC CLEAR

GAL

316 SS



| Part No. | Part No. | Part No. | Description | Set screw length mm | Clearance mm | fixing range mm | T _{inst} (Nm) | Qty |
|-------------------|-------------------|-------------------|--|---------------------|--------------|-----------------|------------------------|-----|
| BXB-BQ1Z06 | | | BoxBolt M6-SIZE 1 ETA HSS Cavity Bolt | 45 | 11 | 5/29 | 13 | 100 |
| BXB-BQ1Z08 | BXB-BQ1G08 | BXB-BQ1S08 | BoxBolt M8-SIZE 1 ETA HSS Cavity Bolt | 50 | 14 | 5/26 | 25 | 50 |
| BXB-BQ2Z08 | BXB-BQ2G08 | BXB-BQ2S08 | BoxBolt M8-SIZE 2 ETA HSS Cavity Bolt | 70 | 14 | 18/46 | 25 | 50 |
| BXB-BQ3Z08 | BXB-BQ3G08 | BXB-BQ3S08 | BoxBolt M8-SIZE 3 ETA HSS Cavity Bolt | 90 | 14 | 30/66 | 25 | 40 |
| BXB-BQ1Z10 | BXB-BQ1G10 | BXB-BQ1S10 | BoxBolt M10-SIZE 1 ETA HSS Cavity Bolt | 50 | 18 | 5/23 | 45 | 25 |
| BXB-BQ2Z10 | BXB-BQ2G10 | BXB-BQ2S10 | BoxBolt M10-SIZE 2 ETA HSS Cavity Bolt | 70 | 18 | 18/43 | 45 | 25 |
| BXB-BQ3Z10 | BXB-BQ3G10 | BXB-BQ3S10 | BoxBolt M10-SIZE 3 ETA HSS Cavity Bolt | 90 | 18 | 35/63 | 45 | 25 |
| BXB-BQ1Z12 | BXB-BQ1G12 | BXB-BQ1S12 | BoxBolt M12-SIZE 1 ETA HSS Cavity Bolt | 55 | 20 | 5/25 | 80 | 25 |
| BXB-BQ2Z12 | BXB-BQ2G12 | BXB-BQ2S12 | BoxBolt M12-SIZE 2 ETA HSS Cavity Bolt | 80 | 20 | 20/50 | 80 | 20 |
| BXB-BQ3Z12 | BXB-BQ3G12 | BXB-BQ3S12 | BoxBolt M12-SIZE 3 ETA HSS Cavity Bolt | 100 | 20 | 40/70 | 80 | 20 |
| BXB-BQ1Z16 | BXB-BQ1G16 | BXB-BQ1S16 | BoxBolt M16-SIZE 1 ETA HSS Cavity Bolt | 75 | 26 | 5/35 | 190 | 10 |
| BXB-BQ2Z16 | BXB-BQ2G16 | BXB-BQ2S16 | BoxBolt M16-SIZE 2 ETA HSS Cavity Bolt | 100 | 26 | 30/60 | 190 | 10 |
| BXB-BQ3Z16 | BXB-BQ3G16 | BXB-BQ3S16 | BoxBolt M16-SIZE 3 ETA HSS Cavity Bolt | 120 | 26 | 55/80 | 190 | 10 |
| BXB-BQ1Z20 | BXB-BQ1G20 | BXB-BQ1S20 | BoxBolt M20-SIZE 1 ETA HSS Cavity Bolt | 100 | 33 | 8/42 | 300 | 5 |
| BXB-BQ2Z20 | BXB-BQ2G20 | BXB-BQ2S20 | BoxBolt M20-SIZE 2 ETA HSS Cavity Bolt | 120 | 33 | 35/72 | 300 | 5 |
| BXB-BQ3Z20 | BXB-BQ3G20 | BXB-BQ3S20 | BoxBolt M20-SIZE 3 ETA HSS Cavity Bolt | 150 | 33 | 65/102 | 300 | 5 |

Limit State Design Performance Data BOXBOLT

| Description & Part Number | | | Dimensional / Installation Information | | | | | | | | | Design Capacities | | | |
|---------------------------|---------------------------|------|--|----------------------|-----|-----------------------------|-----------------------|------------|------------|----------------|-------------|--|------------|-------------------------|------------|
| BoxBolt | Product code (* = finish) | Size | Set screw length (mm) | Fixing range (dim x) | | Across Flats of collar (mm) | Collar thickness (mm) | Dim A (mm) | Dim B (mm) | Hole size (mm) | Torque (Nm) | Galvanized (* = G) Zinc Plated (* = Z) | | Stainless Steel (* = S) | |
| | | | | Min | Max | | | | | | | Tension (kN) | Shear (kN) | Tension (kN) | Shear (kN) |
| M06 | BXB-BQ1*06 | 1 | 45 | 4 | 24 | 17 | 5 | 30 | 11 | 11 +1.0,-0.25 | 13 | 11.0 | 15.0 | 10.2 | 14.1 |
| M08 | BXB-BQ1*08 | 1 | 50 | 5 | 26 | 22 | 6 | 35 | 13 | 14 +1.0,-0.25 | 25 | 18.9 | 26.6 | 18.5 | 25.3 |
| | BXB-BQ2*08 | 2 | 70 | 18 | 46 | 22 | 6 | 35 | 13 | 14 +1.0,-0.25 | 25 | 18.9 | 26.6 | 18.5 | 25.3 |
| | BXB-BQ3*08 | 3 | 90 | 30 | 66 | 22 | 6 | 35 | 13 | 14 +1.0,-0.25 | 25 | 18.9 | 26.6 | 18.5 | 25.3 |
| M10 | BXB-BQ1*10 | 1 | 50 | 5 | 23 | 24 | 7 | 40 | 15 | 18 +1.0,-0.25 | 45 | 33.4 | 46.8 | 29.2 | 45.7 |
| | BXB-BQ2*10 | 2 | 70 | 18 | 43 | 24 | 7 | 40 | 15 | 18 +1.0,-0.25 | 45 | 33.4 | 46.8 | 29.2 | 45.7 |
| | BXB-BQ3*10 | 3 | 90 | 35 | 63 | 24 | 7 | 40 | 15 | 18 +1.0,-0.25 | 45 | 33.4 | 46.8 | 29.2 | 45.7 |
| M12 | BXB-BQ1*12 | 1 | 55 | 5 | 25 | 26 | 8 | 50 | 18 | 20 +1.0,-0.25 | 80 | 43.0 | 61.0 | 42.5 | 57.9 |
| | BXB-BQ2*12 | 2 | 80 | 20 | 50 | 26 | 8 | 50 | 18 | 20 +1.0,-0.25 | 80 | 43.0 | 61.0 | 42.5 | 57.9 |
| | BXB-BQ3*12 | 3 | 100 | 40 | 70 | 26 | 8 | 50 | 18 | 20 +1.0,-0.25 | 80 | 43.0 | 61.0 | 42.5 | 57.9 |
| M16 | BXB-BQ1*16 | 1 | 75 | 5 | 35 | 36 | 9 | 55 | 20 | 26 +2.0,-0.25 | 190 | 76.8 | 111.4 | 79.1 | 105.3 |
| | BXB-BQ2*16 | 2 | 100 | 30 | 60 | 36 | 9 | 55 | 20 | 26 +2.0,-0.25 | 190 | 76.8 | 111.4 | 79.1 | 105.3 |
| | BXB-BQ3*16 | 3 | 120 | 55 | 80 | 36 | 9 | 55 | 20 | 26 +2.0,-0.25 | 190 | 76.8 | 111.4 | 79.1 | 105.3 |
| M20 | BXB-BQ1*20 | 1 | 100 | 8 | 42 | 46 | 11 | 70 | 25 | 33 +2.0,-0.25 | 300 | 134.4 | 183.9 | 123.5 | 176.2 |
| | BXB-BQ2*20 | 2 | 120 | 35 | 72 | 46 | 11 | 70 | 25 | 33 +2.0,-0.25 | 300 | 134.4 | 183.9 | 123.5 | 176.2 |
| | BXB-BQ3*20 | 3 | 150 | 65 | 102 | 46 | 11 | 70 | 25 | 33 +2.0,-0.25 | 300 | 134.4 | 183.9 | 123.5 | 176.2 |

Note: 1) The above loads are Design Capacities based on independent testing conducted in accordance with EAD 330001-00-0602 and referenced in ETA 15/0768. Design Capacities may be used in design according to AS 4100. Design Capacities above incorporate a Capacity Factor (ϕ) for Strength Limit States of 0.8 in accordance with table 3.4 of AS 4100 for Bolted Connections.

2) For combined loading applications (Tension & Shear) BOXBOLT must comply with the requirements highlighted in AS 4100 section 9.3.2.3 (Bolts subject to combined shear and tension).

3) The strength of the material BOXBOLT is connecting into should be checked for structural capacity by a suitability qualified structural engineer responsible for the application.

* = fill the code with Z for zinc plated finish, G for Hot Dip Galvanized, and S for Stainless Steel A4

BOXBOLT diameter and positioning of holes

| Dia | Dim A | Dim B | Dim C | Tolerance |
|------------|-------|-------|-------|-------------|
| M06 | 30 | 11 | 11 | +1.00 -0.25 |
| M08 | 35 | 13 | 14 | +1.00 -0.25 |
| M10 | 40 | 15 | 18 | +1.00 -0.25 |
| M12 | 50 | 18 | 20 | +1.00 -0.25 |
| M16 | 55 | 20 | 26 | +2.00 -0.25 |
| M20 | 70 | 25 | 33 | +2.00 -0.25 |

Note: Min. edge distance = Dim B plus the thickness of the hollow section.

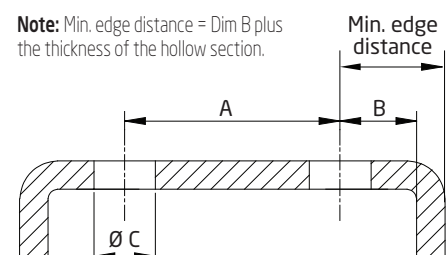

BOXBOLT installation

- 1 Drill the sections to be fixed, ensuring that the holes required have the correct diameter and spacing. (See Dim C overleaf).
- 2 De-burr the holes.
- 3 Position the sections flush against each other, ensuring:
 - The two sections are lined up and are flush without any gap. If necessary, use a clamp to hold the two sections and prevent a gap forming
 - the holes are aligned, using a mandrel if necessary
- 4 Advice: Use of the special BoxSok™ tool is recommended for installation. If you are using this tool, go to the section below.
- 5 Position the Bolts in the holes. Check the collar is resting flat on the section with no gap.
- 6 Hold the collar in position using a suitable open-ended wrench, then tighten the bolt to the torque specified. An impact tool/wrench is recommended for initial tightening to speed up installation. Do not over tighten the BoxBolt. A torque wrench should always be used for final tightening to the correct torque value as specified in this document.
- 7 Remove the tool and check the tightening torque on the bolt. If necessary, correct the tightening torque. (Always use the manufacturers recommended torque on the reverse of this page, column headed "Torque" in the technical table.)

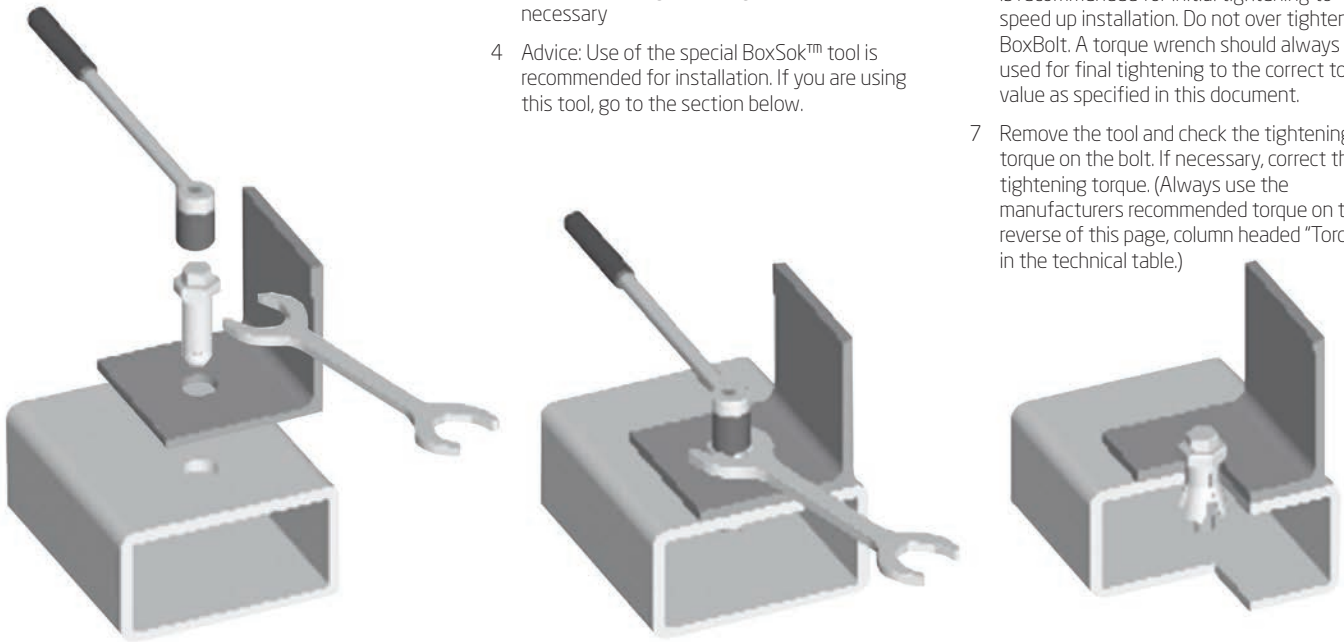

BOXBOLT BoxSok

The **BoxSok** Installation Tool is a unique rapid assembly tool designed to simplify and speed up BoxBolt installation. Allows to expand the cavity bolt with no need of any additional tool, and in one single installation step. and in one single step. **BoxSok** is available to suit all BoxBolt BOLT diameters.

Fit the **BoxSok** onto the BoxBolt, so that the **BoxSok** is resting on the section. If

necessary, adjust the **BoxSok** so that it fits properly on the BoxBolt.

Hold the **BoxSok** straight and tighten the bolt using the BoxSok (proceed to Step 7 of the BoxBolt installation instructions)

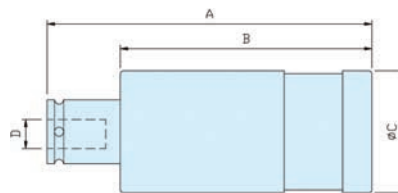

| Dia BOXSOK | Dim A (mm) | Dim B (mm) | Dim c (mm) | Drive D (in) |
|------------|------------|------------|------------|--------------|
| M06 | 111.5 | 85.0 | 30.0 | 1/4" |
| M08 | 112.0 | 85.5 | 34.0 | 3/8" |
| M10 | 113.0 | 86.5 | 38.0 | 3/8" |
| M12 | 114.0 | 87.5 | 42.0 | 3/8" |
| M16 | 114.5 | 88.0 | 50.0 | 1/2" |
| M20 | 115.5 | 89.0 | 59.0 | 1/2" |

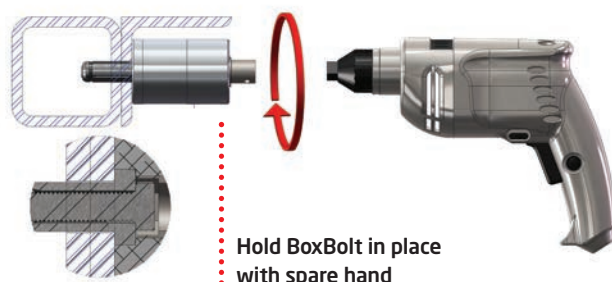
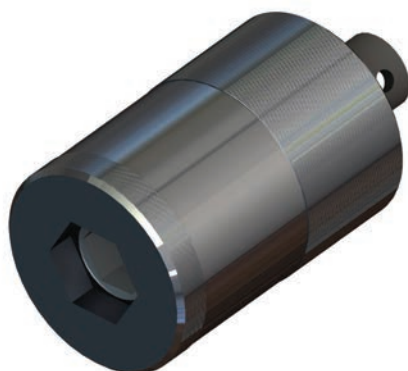

OR



Hold BoxBolt in place with spare hand



BOXBOLT applications



Two hollow sections at 90 degrees using an end plate



Hollow section below an I-Beam at 90 degrees using a combination of BOXBOLT and BEAMCLAMP fixings



Two hollow sections at 90 degrees using angle brackets

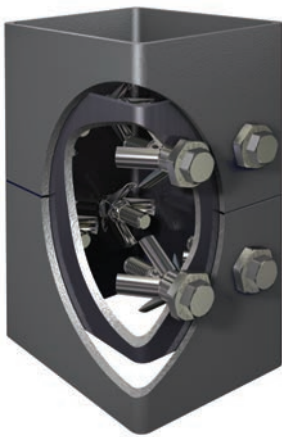

Hollow section sleeve connection creating an aesthetic joint from the outside



Angle to vertical hollow section post



Rigging point to outside of hollow section



Side fixing of handrail base to hollow section



Top fixing of handrail base to hollow section



Glazing bracket to hollow section

BOXBOLT vs other fixing methods



Drilling & Tapping

- Drill pilot holes
- Tap holes
- Connect bolts
- Tighten bolts to torque
- Weak connection

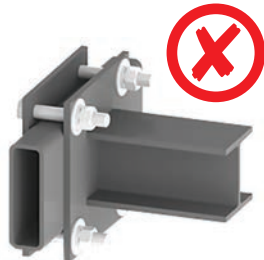

Strapping

- Place plate and bolts around one side
- Place plate on other side and align bolts
- Connect nuts and washers
- Tighten equally to avoid twisting

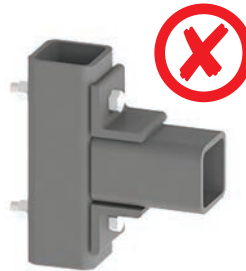

Thru bolting

- Drill clearance holes
- Drill clearance holes other side
- Connect bolts through aligned holes
- Tighten bolts to torque



Welding

- Prepare surfaces to weld
- Position welding equipment
- Perform weld
- Leave to cool (under supervision)
- Perform proof test on the weld



- Drill clearance holes
- Insert BoxBolts
- Tighten BoxBolts to torque





BOXBOLT references



Mercedes-Benz Stadium - Atlanta
MOVING ROOF HSS SECTIONS

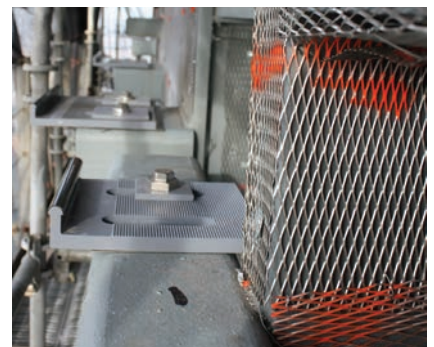
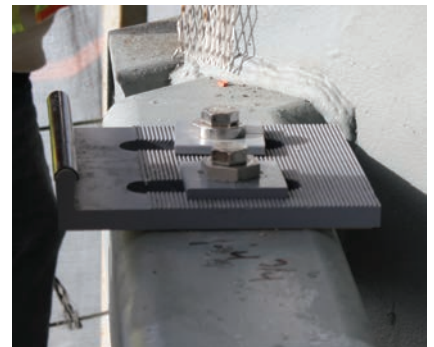

Three World Trade Center - NY
FACADE - BRACKETS TO THE STEEL STRUCTURE



TDS | 1033.2

ICCONS® PTY LTD

VICTORIA - HEAD OFFICE
383 Frankston Dandenong Road,
Dandenong South, Vic, 3175
P: **03 9706 4344**
F: **03 9768 3329**

NSW Branch
Unit A, 17 Seddon Street,
Bankstown,
New South Wales, 2200
P: **02 9791 6869**
F: **02 9790 8404**

QLD Branch
42-44 Nealdon Drive
Meadowbrook,
Queensland, 4131
P: **07 3200 6455**
F: **07 3299 7548**

S.A Branch
29-31 Weaver Street,
Edwardstown,
South Australia 5039
P: **08 8234 5535**
F: **08 8354 4689**

W.A. Branch
90 Christable Way, Landsdale,
Western Australia, 6065
P: **08 6305 0008**
F: **08 6305 0011**

NORTHERN TERRITORY
Unit 1, 14 Menmuir Street,
Winnellie,
Northern Territory 0820
P: **08 8947 2758**

NEW ZEALAND
Sesto Fasteners
5E Piermark Road, Albany,
Auckland,
New Zealand 0630
P: **+64 9415 8564**
E: **sestofasteners@gmail.com**

ICCONS (Thailand) Co. Ltd.
55 Phetkasem 62/3, Bangkhae,
Bangkok 0160
P: **+ 66 2 801 0764**
F: **+ 66 2 801 0764**
M: **+ 66 8 1 710 8745**
E: **icconsthailand@hotmail.com**

www.iccons.com.au

6/3/2021



A KEE SAFETY PRODUCT